

# Contradictions in the Conclusions, Science and Data in the UN OPCW Fact-Finding Mission Report S/1731/2019 on the Chlorine Cylinder Attack on 7 April 2018 in Douma, Syria

Theodore A. Postol  
Professor Emeritus of Science, Technology and National Security Policy  
Massachusetts Institute of Technology  
June 3, 2019, Palo Alto, California

This document provides a limited assessment of the 1 March 2019 OPCW Fact-Finding Mission Report S/1731/2019 on the alleged use of toxic chemicals in Douma, Syria on 7 April 2018. The OPCW report was provided to the UN Security Council on 1 March 2019.

This limited assessment focuses on the OPCW report's analyses and findings related to an incident where a chlorine cylinder was found on the roof of a four-story building with its front-end lodged in a hole in the roof. The roof of the building was constructed of steel reinforced concrete that had been poured in place during construction. An image of the cylinder lodged in a hole in the roof concrete panel is shown to the right. Also shown below and to the right is an image of the building provided in the UN report with information about victims of the attack as determined by the UN analysis of this event.

The more than 30 deaths associated from this alleged event could have occurred due to the rapid injection of a very dense draft of chlorine into the top floor of the building. Since chlorine is heavier than air, the chlorine would have settled quickly towards lower floors at concentrations that were so high that it could have rendered people unconscious before they could escape. Once unconscious, the effects of the chlorine would then have been fatal. Hence, on the surface, this scenario has the appearance of high plausibility.

A review of the science-based analysis that appears to have been aimed at supporting the conclusions of the UN OPCW Fact-Finding Mission Report S/1731/2019 shows that the science-based analysis in the report completely contradict both the report's conclusions and observed data.

It therefore appears to be inescapable that this report must have been written without regard for the facts collected by the Fact Finding Mission or the results of the included science-based technical analyses.

**FIGURE A.6.2 CYLINDER WITH VISIBLE DAMAGE LIKELY ORIGINATING FROM THE MESH**



The FFM team noted that a similar crater (see photos below) was present on a nearby building.

**FIGURE 6: 3D LAYOUT OF LOCATION 2 WITH DISTRIBUTION OF ROOMS AND REPORTED LOCATIONS OF ALLEGED VICTIMS**

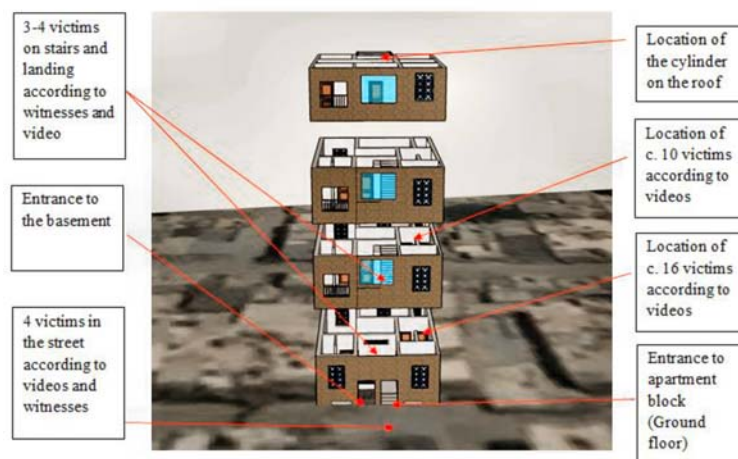

In addition to showing calculation results that contradict the findings of the OPCW report, the OPCW technical analysis itself appears to have used inputs that appear to have been artificially chosen to obtain computational results that could superficially appear consistent with a conclusion that the scene of the attack was real.

In particular, the assumed impact speed of the chlorine cylinder would have required that it be dropped from a helicopter at an altitude of between 50 and 250 m, with the most likely altitudes being between 50 and 130 m. At these altitudes helicopters would be highly vulnerable to ground fire from AK-47 assault rifles, or even hand guns – which are ubiquitous in these environments. Evidence from earlier studies of Syria's barrel bombing campaigns performed by my colleague Richard Lloyd indicate that the altitude used by Syrian helicopters is often close to about 2 km or higher. This choice of an operational altitude is consistent with procedures aimed at operating above altitudes where damage can occur from anti-aircraft fire from AK-47 assault rifle.

This choice of an implausibly low altitude for a helicopter dropping chlorine cylinders is driven by an artificial need for an analytical input assumption for the chlorine cylinder to impact the concrete panel roof at an extremely low speed of roughly 30 m/s. A higher speed would have resulted in an analytical outcome where the cylinder penetrated through the roof rather than coming to rest on the roof. For example, if a helicopter dropped a chlorine cylinder from a dangerously low altitude of 500 meters, subject to potentially lethal fire from AK-47s, the cylinder would have impacted the concrete panel roof at 100 m/s, completely penetrating the roof and likely even the floor of the room it entered.

### **A Detailed Explanation of the OPCW Bogus Science-Based Calculation**

The diagram below is extracted from page 57 (Annex 6) of the OPCW report S/1731/2019. This diagram is supposed to have provided the science-based component of the report's analysis of *Location 2* where the chlorine cylinder was found on the roof of a four-story building with its front-end inserted into a hole on the roof. If this scene indicated what actually occurred, a reasonable analysis would produce a finding that almost the entire liquefied chlorine contents in the cylinder would have been injected into the top floor of the building.

However, as will be shown from a simple analysis of this diagram, the science-based calculation does not reproduce the results observed and reported by the Fact-Finding Mission and it is also not consistent with the reports stated conclusions.

**Figure A.6.7(a) from page 57 (Annex 6) of OPCW report S/1731/2019.**

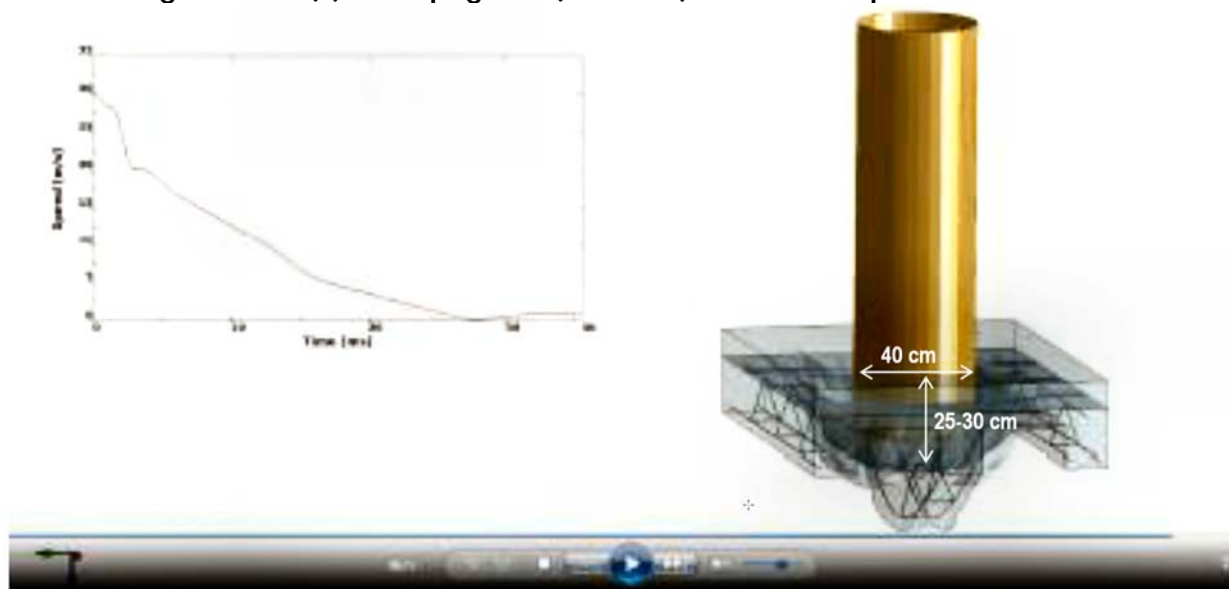
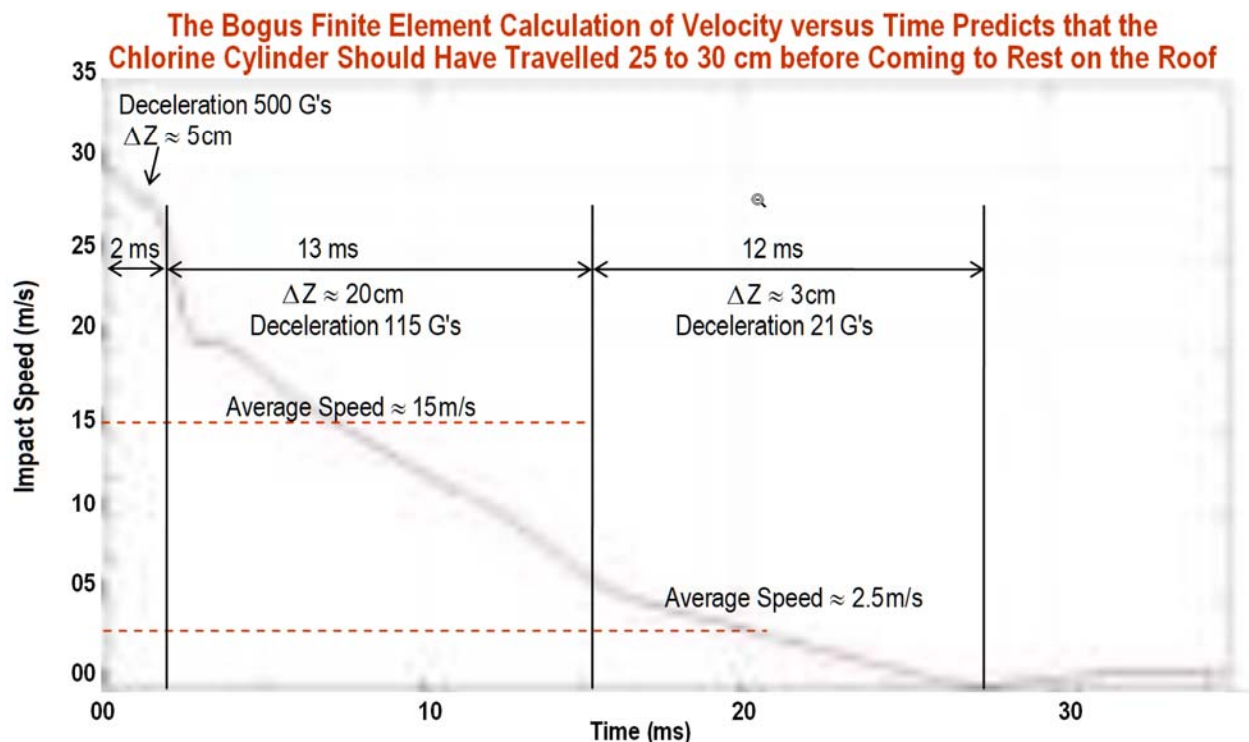

Figure A.6.7(a) from page 57 (Annex 6) of UN report S/1731/2019. This figure shows the results of a finite element calculation that is aimed at explaining how a chlorine cylinder of 40 cm diameter came to rest on the concrete reinforced roof of a building where it is alleged that more than 30 people died inside from the sudden injection of chlorine gas from the cylinder. One of several critical issues raised about this calculation is why it is assumed that the cylinder hit the roof at 30 m/s – which could indicate that it was dropped at an altitude of no more than 50 m above the building. Such an attack would have exposed a helicopter to extensive ground fire, even including ground fire from handguns.

An informed inspection of the results of the penetration-calculation shown in the figure A.6.7(a) show that the 40 cm diameter cylinder penetrated reinforced concrete roof panel to a depth of 25 or 30 cm, which is roughly the thickness of the roof. The diagram that shows results of the calculation indicates that the steel rebar in the roof panel was plastically deformed by the ongoing impact but the rebar prevented the cylinder from passing through the roof. This interpretation of the diagram exactly matches the detailed information provided in the graph on the left in figure A.6.7(a).

The graph below is a blowup from figure A.6.7(a) of the velocity versus time of the cylinder during the process of coming to rest on the roof. We do not understand why this diagram is so unclear, as a similar diagram of a roof-penetration on page 18 of the same report has a highly readable graph. Nevertheless, it was possible to establish the scales on the graph below, which allows a detailed assessment of the impact process predicted by the calculation. The prediction of this calculation is that the cylinder would produce a hole in the roof but not penetrate into the room below.

As can be seen by inspecting the labeled graph below, the cylinder initially encounters the surface of the roof and decelerates at a rate of 500 G's as it travels about 5 cm within 2 ms, crushing the brittle concrete in front of it. Once the concrete in front of the cylinder is pulverized, the steel rebar in the concrete panel continues to slow the progress of the cylinder as the rebar plastically deforms under the forward momentum of the cylinder. During this phase of the impact the deceleration of the cylinder has dropped by nearly a factor of 5 to 115 G's as it travels an additional 20 cm to the point of nearly penetrating the concrete panel. In the next 12 ms of the impact the deceleration rate drops to nearly 25 times lower than the initial deceleration and the cylinder travels only about 3 cm forward after penetrating the full concrete panel as the rebar continues to stretch without failing – leaving the canister in a position where it has not penetrated the roof.



It should be clear that if the cylinder were traveling at a speed even slightly in excess of 30 m/s, it would have caused the rebar to fail as it penetrated the roof into the room below. This seems to explain the implausibly low impact speed of 30 m/s impact speed which would only occur if a helicopter dropped the cylinder from an altitude of roughly 50 m.

In order for this calculation to accurately represent the situation associated with this presumed attack, the data from the scene reported by the Fact-Finding Mission would have shown a hole in the concrete that is roughly the diameter of the impacting cylinder (40 cm) along with steel rebar that had not completely failed and was stopping the cylinder from falling into the room below.

The actual scene that was found by the Fact-Finding Mission is shown in the labeled photograph shown immediately below.

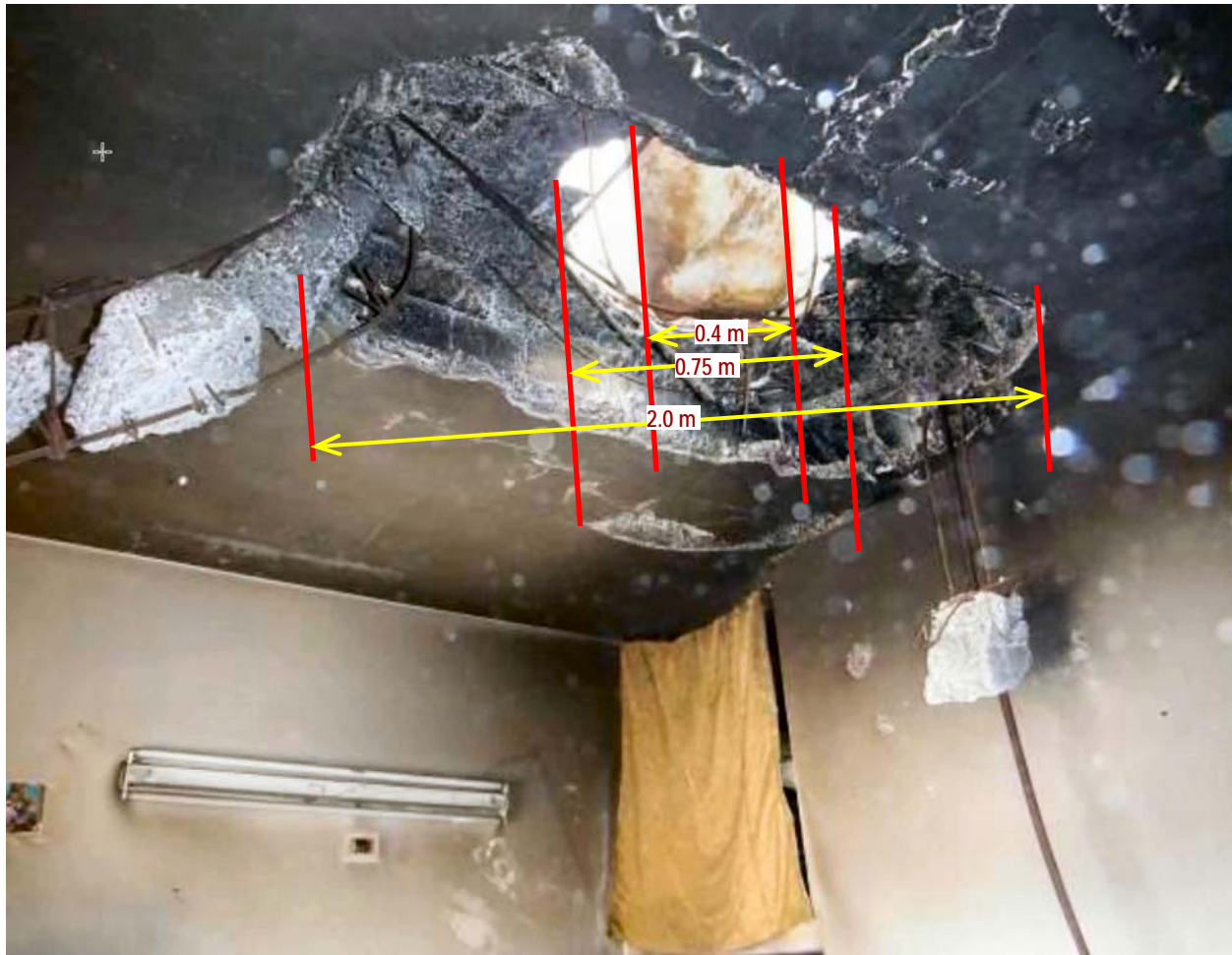

The labeled photograph above of the hole in the roof allegedly caused by the impact of a chlorine cylinder shows that the physical scene looks nothing like the predictions of the science-based finite element calculations. The diameter of the hole is nearly twice that of the cylinder and the steel rebar that was supposed to stop the cylinder from penetrating through the roof is instead completely shattered and bent away from the forward direction by more than 60°. As will be discussed later. This photograph shows that the crater was produced by an explosion on the roof which had nothing to do with the impact of a chlorine cylinder. These discrepancies simply mean that the cylinder was placed on the roof after the hole was produced by the explosion of a mortar shell or artillery rocket.

An inspection of the photograph quickly shows that the diameter of the hole predicted by the finite element calculation does not match the diameter of the cylinder. It also shows that the rebar failed catastrophically due to an extremely intense impulse that was considerably larger than that associated with the low speed impact of a chlorine cylinder. This kind of shattering and bending of the rebar is a classic and well-known result of an explosion shockwave which produced the hole in the roof. Also worthy of note is that the finite element calculation predicts that the rebar would be holding the cylinder in place. Thus, the conclusion stated by the OPCW report that the hole in the roof was produced by the falling cylinder is completely unsupported by both the observed evidence and the misleading finite element calculation.

To summarize, the presumed inputs to the science-based finite element calculations were carefully chosen to get a result where the cylinder did not penetrate through the steel reinforced concrete roof. The input that was chosen required a helicopter drop-height that would have made it extremely vulnerable to ground fire from assault rifles (particularly the infamous AK-47). The results of the calculation was inconsistent with the observed crater at the alleged attack-scene, which showed that the rebar in the concrete failed catastrophically as it was blown (by the detonation of an artillery rocket or mortar at the surface of the roof) to an angle of more than 60° relative to the incoming direction of the cylinder. The bogus calculation with the artificially chosen inputs instead showed that the rebar should have been intact, as the plastic deformation of the rebar was the only mechanism that would have led to the misleading prediction that the cylinder would come to a stop without penetrating the roof. Thus, the results of the bogus science-based calculations were incompatible with the observed facts at the site of the crater and with the conclusions reported by the OPCW political leadership.

## Information on the Science-Based State-of-The-Art in Predicting the Effects of Explosions and Object Impacts on Reinforced Concrete Panels

As one would expect, the science and technology for predicting the behavior of complex mechanical systems like reinforced concrete is a highly complex area of research. This research is not only motivated by curiosity, but it is strongly advanced by the important life-saving results of such detailed calculations.

An important characteristic of concrete is that it is brittle. By definition, such a material is not flexible but will develop cracks and fail catastrophically when subjected to stresses that are sufficiently large. Concrete can be substantially strengthened by embedding reinforcing steel rebar or other strong but flexible materials within it. The rebar performs the function of maintaining the strength of the material when it is flexed rather than failing catastrophically as is the case with the surrounding brittle material.

The drawing immediately below shows how a concrete panel might be breached by the effects of a nearby explosion that is sufficiently intense to generate a hole in the concrete panel.

Initially the shockwave generated by the detonation reaches the surface of the concrete panel. The pressure from the shockwave causes the concrete at the surface to be compressed. The compressed region of the concrete then presses against the adjacent layer of concrete causing it to be compressed. This process continues until the region of compression reaches the far face of the concrete panel. At this location there is no massive adjacent region of concrete to absorb the forward momentum of the propagating compression. The now unconstrained outward motion of the compressed concrete carries it into the surrounding environment at high speeds, creating intense forces on the concrete behind the compression causing that layer of brittle concrete to catastrophically fail. This results in the “spallation” of the concrete at the surface. In these circumstances concrete fragments can be launched to high speeds causing damage and serious injury to people and objects in line-of-sight of the wall.

During the process of spallation a reflected shock is generated that propagates back toward the top of the panel. This reflected shock is less intense and thereby results in a somewhat lower level of spallation at the top of the panel.

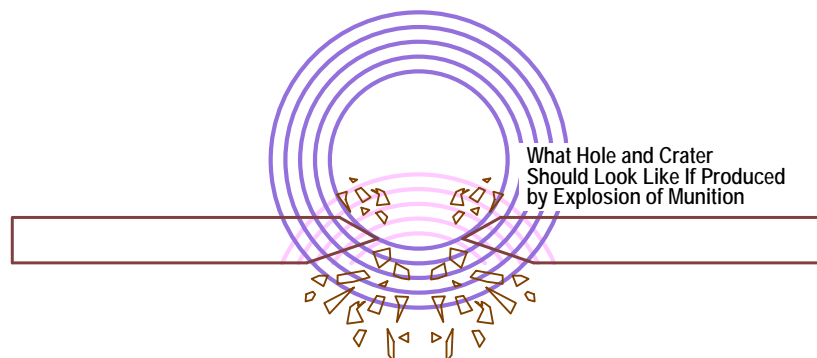

The next drawing at the top of the next page shows how a concrete panel can be breached by the impact of an object. In this case, the impact at the surface tends to crush the concrete immediately in front of the penetrating object. The penetrating object also creates a shockwave that propagates to the far wall of the panel causing spallation at that location. A reflected shockwave is also generated which then leads to further spallation at the near wall of the panel.

A very important additional phenomenon associated with the impact of an object can be the creation of a hole due to a process that is generally referred to as “tunneling.” Because the breach created by the penetrating object results in the crushing and pushing of brittle concrete as the object moves forward, the diameter of the hole produced by the impact of the object will be very close to that of the penetrating object. This means that a hole created by a 40 cm diameter chlorine cylinder should be close to 40 cm in diameter – not nearly twice the diameter as shown in the data from the Fact-Finding Mission photographs of the hole in the roof that the OPCW report incorrectly ascribes to an impact with the chlorine cylinder.

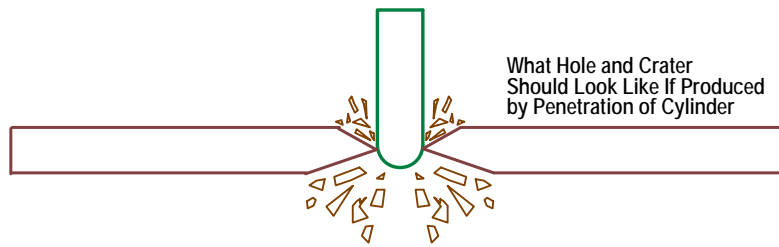

The image below summarizes the mismatches between the predicted characteristics of the hole in the roof and the observed characteristics of the hole in the roof.

The diagram on the left side of the image shows the predicted radius of the hole produced by the penetrating chlorine cylinder, and the radii of the areas of predicted spallation at the near and far walls of the impacted panel. Also shown in the diagram on the left is plastic-deformed rebar which the calculations predict will prevent the cylinder from passing through the brittle concrete panel. This predicted outcome is critically dependent on the assumption that the cylinder impacts the panel at 30 m/s. A higher impact speed will result in the cylinder breaching the panel.

The diagram on the right shows the radii of the observed front and back spallation regions and the diameter of the actual hole in the crater as observed by the Fact-Finding Mission. It is clear that the crater hole is roughly twice the diameter of what should have been the case if the hole was created by the penetration of the chlorine cylinder. It is also clear that the rebar in the observed photographs of the hole on the far surface of the panel failed completely and were blown open. It is therefore clear that the observed data associated with the crater is completely different from the predictions of the finite element calculation.

Since the finite element calculation does not produce a result that matches what is observed, it is a clear indication that the assumptions associated with the production of the calculation do not apply to this particular situation. We know for a fact that the supercomputer calculations done for the crater at Khan Sheikhoun essentially exactly produce all of the important observed characteristics of that scene. The fidelity of that particular calculation was striking relative to what is produced in the case of the OPCW report.

### Complete Mismatch between the Observed and Calculated Properties (Dimensions) of the Studied Crater

Incorrect Predicted Properties of Alleged UN Finite Element Calculation to Predict Observable Properties of Crater

Actual Observed Properties of the Crater at Location 2 in Douma, Syria

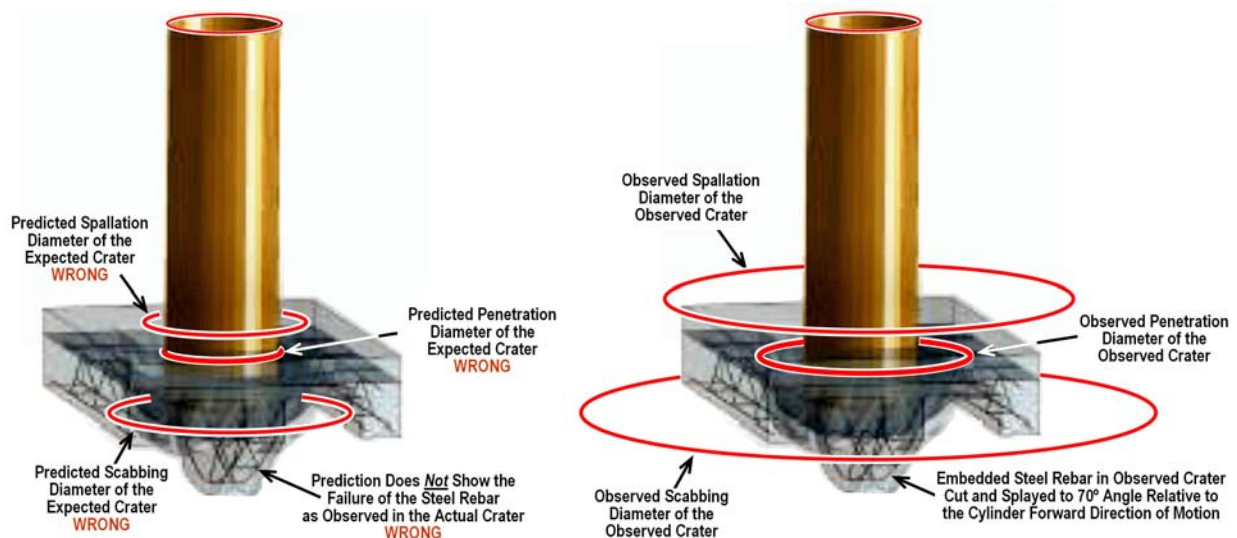

The attached appendix contains diagrams and references to technical articles that discuss the various mechanisms associated with breaching of concrete panels by either explosive detonations or by impact with penetrating objects.

These materials have been collected for the perusal of readers of this document. There are many more articles than shown in this appendix.

### Further Evidence That Indicates the Hole on the Roof Was Produced by the Explosion of an Artillery Rocket or Mortar Shell

Figure A.6.2 shown below from page 54 of the OPCW report S/1731/2019 shows the dimensions of the spallation radius of the hole that was supposedly produced by the impact of the chlorine cylinder in the photograph. The dimensions of the spallation radius were determined by scaling the already determined 0.75 m diameter of the tunneling hole, which was determined from a photograph of the underside of the crater at the top of the next page.

#### **FIGURE A.6.2 CYLINDER WITH VISIBLE DAMAGE LIKELY ORIGINATING FROM THE MESH**



The FFM team noted that a similar crater (see photos below) was present on a nearby building.

As can be seen from the photograph at the top of the next page, the diameter of the cylinder relative to the hole in the roof can be clearly seen from the room below. Since the cylinder diameter is known to be 0.4 m the diameter of the hole can be reasonably estimated by simply comparing the two diameters. By combining the information derived from the photograph from the room below with the information from the photograph above, we can determine the diameter of the spallation region on the surface of the roof.

The next photograph, figure A.6.3 from the top of page 55 in S/1713/2019 shows a photograph of the crater on the adjacent building. Inexplicably the report S/1713/2019 provides no information about the dimensions of this crater. This omission is itself an indication of serious problems with S/1713/2019. The provided photographs essentially ignore potentially informative information that could be used to get an estimate of the size of the crater.

We believe that there must be photographs that would make it possible to obtain an estimate of the size of this crater.

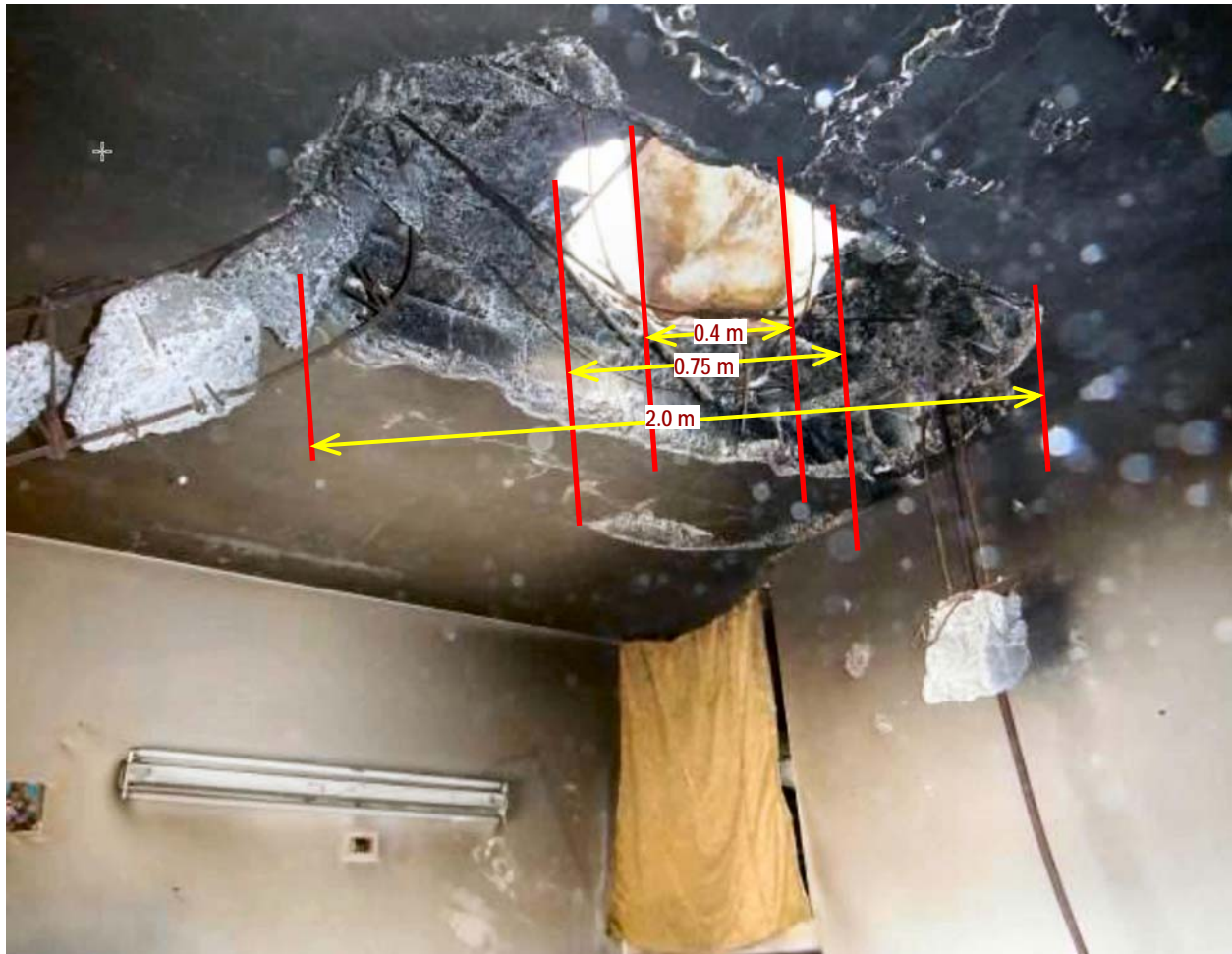

S/1731/2019  
Annex 6  
page 55

**FIGURE A.6.3 ADJACENT ROOF SHOWING A CRATER SIMILAR TO THE ONE ON THE ROOF TERRACE AT LOCATION 2**



6. The team was not able to climb on to the top of the building due to the security restrictions, but was able to observe damage in the corner of the balcony location above the crater.

We were able to take the measurements of the relative sizes of the diameters of the hole in the roof and the spallation area and project them over the crater after making minor adjustments for the non-vertical viewing



angle of the camera. As can be seen from the overlays of the crater, the ratio of the internal and external diameters of the crater on the adjacent building exactly matches the ratio of the internal and external diameters of the hole on the building that the OPCW report alleges was created by the impact of a chlorine cylinder.

It is clear that this OPCW claim is not accurate, but what is not clear is why the OPCW did not provide information about the dimensions of this crater even if it had to be derived from scaling of photographic evidence.

This kind of omission of information is, unfortunately, consistent with the OPCW report's numerous inconsistencies that do not appear to be explainable as simply due to error.

## Summary

There is absolutely no doubt that the OPCW finding that the chlorine cylinder found at what it identifies as *Location 2* did not produce the hole in the roof that allegedly led to the killing of more than 30 people that the OPCW claims were trapped and poisoned in the building. The OPCW's own science-based technical analysis does not come close to matching what was observed at *Location 2*. The science and technology for producing accurate predictions of what caused the hole in the roof is well-in-hand. All that would be needed would be a calculation that properly assumes the conditions that could lead to the hole. My colleagues and I have already demonstrated that much more complicated situations can be exactly replicated with supercomputer calculations that utilize appropriate assumptions. We have shown that the crater that was allegedly the source of a sarin release at Khan Sheikhoun was instead produced by the explosion of an artillery rocket. That calculation not only predicted the size and shape of the crater, but it also predicted that the rocket motor casing would be embedded in the front of the crater and bent along its axis of symmetry by torques produced during the process of impact. This demonstrates that calculations where appropriate assumptions about the conditions that produced and observable results can be used to determine the exact circumstances that led to the observable results.

In the case of the OPCW's report S/1713/2019, the calculations produced as proof for the findings bear absolutely no relationship to what was observed at the scene. In spite of the fact that these calculations did not produce results that replicated the observable scene, the OPCW report to the UN Security Council misrepresented these calculations as proof. In addition, it appears that the assumed conditions for the calculations were derived due to an effort to replicate a result where the chlorine cylinder did not go through the roof of the building but instead came to rest on the rooftop. In order to replicate this result, the assumptions going into the calculation were distorted to assume an impact velocity of 30 m/s. Thus, the findings of the report did not match either the results of the calculations or the results of observations taken at the scene. Finally, clear supporting evidence that the hole in the roof of the building was produced by a rocket or mortar shell on an adjacent building was not investigated when it unambiguously would have provided additional information that could have been useful for the investigation.

The report S/1713/2019 is also tainted by the same types of barefaced flaws – including overtly contradictory and internally inconsistent assertions – as the report S/2017/904 published on 26 October 2017. In both cases supposedly expert opinions were quoted that could not have been made by any true expert who was genuinely interested in providing accurate technical information in support of the findings. These two cases are unambiguous and require vigorous, comprehensive, and transparent investigations by the UN if the credibility of all the organizations involved is to be preserved.

Sincerely,  
Theodore A. Postol



Professor Emeritus of Science Technology and National Security Policy  
Massachusetts Institute of Technology



# APPENDIX

Examples of data and calculations from the scientific and engineering literature on the effects of explosives and object impacts on concrete panels.

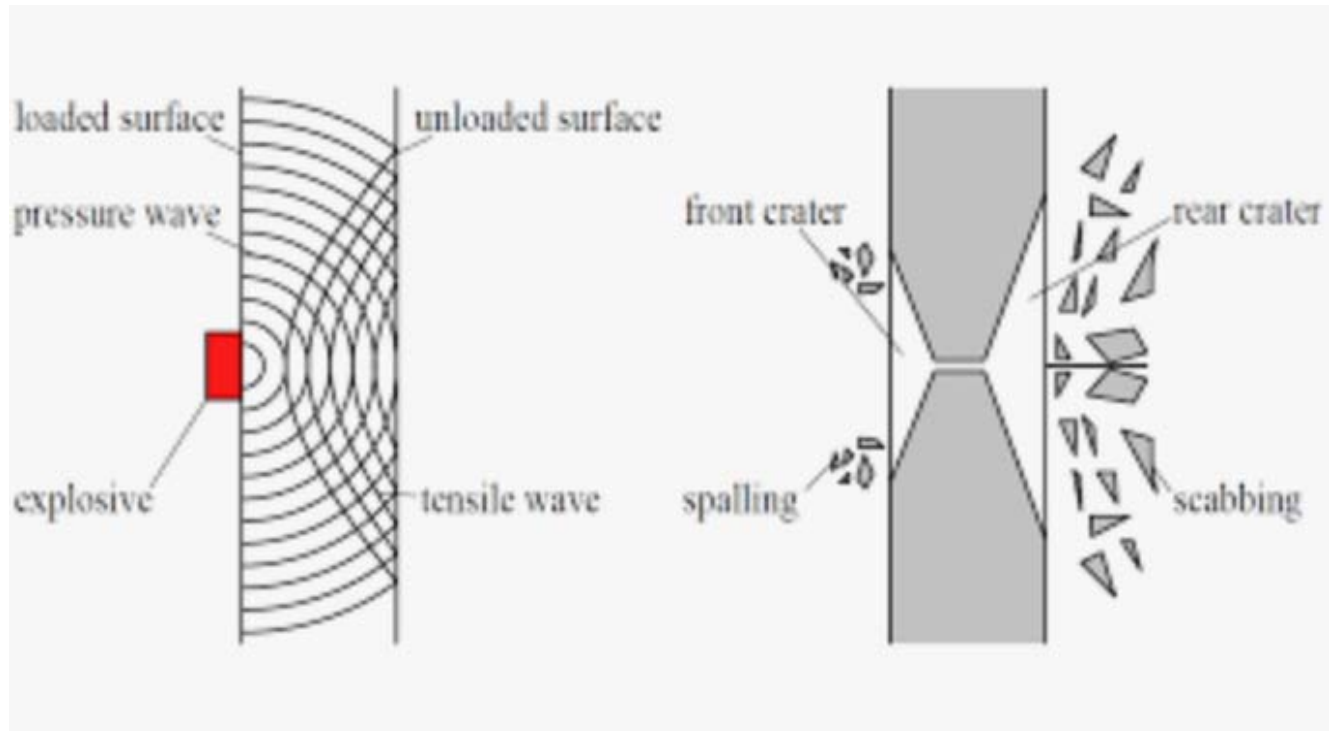

Experimental Investigation on the Blast Resistance of Fiber- Reinforced Cementitious Composite Panels Subjected to Contact Explosions

International Journal of Concrete Structures and Materials Vol.11, No.1, pp.29-43, March 2017  
DOI 10.1007/S40069-016-0179-y  
ISSN 1976-0485 / eISSN 2234-1315

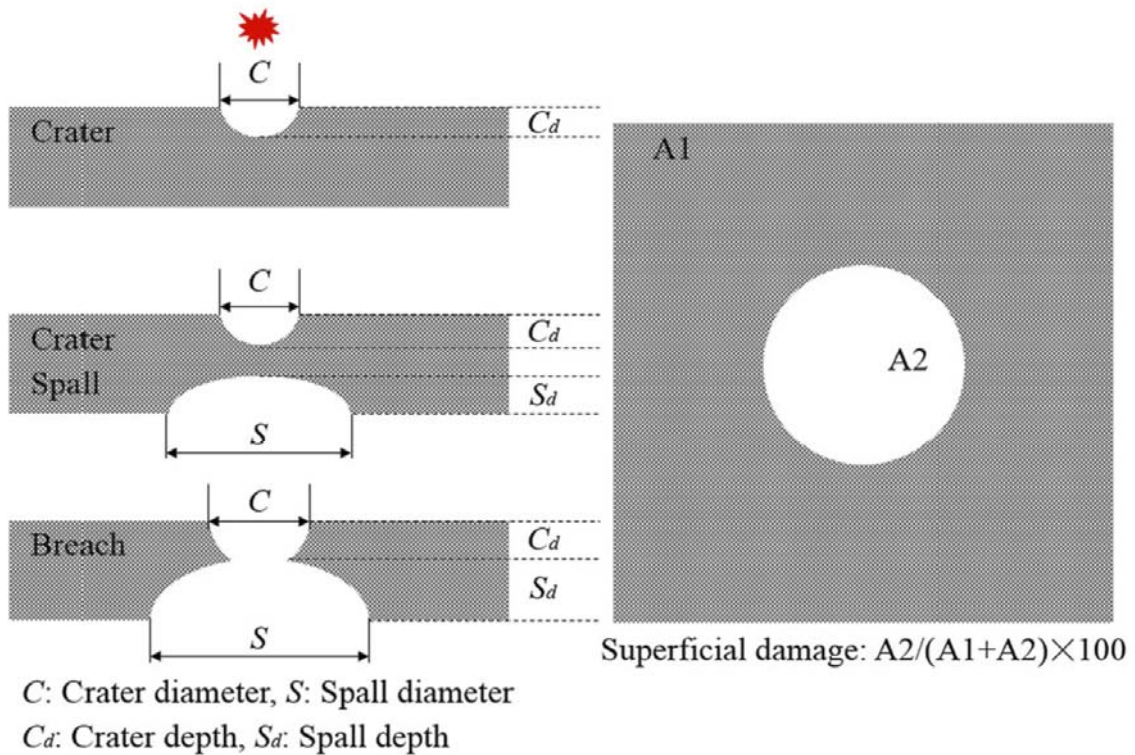

**Fig. 4** Measurement of damage areas in the panels.

Explosive Breaching of Walls with Contact Charges; Theory and Applications  
International Journal of Protective Structures - Volume 6 ■ Number 4 ■ 2015, Page 629  
Alex Remennikov<sup>1</sup>\*, Igor Mentus<sup>2</sup> and Brian Uy<sup>3</sup>

<sup>1</sup>Centre for Infrastructure Protection & Mining Safety, University of Wollongong, Wollongong, NSW, 2522, Australia<sup>2</sup> School of Military Engineering, Kamenetz-Podolsk National Technical University, Kamenetz-Podolsk, Ukraine <sup>3</sup> Centre for Infrastructure Engineering, School of Civil and Environmental Engineering, The University of New South Wales, NSW, Australia

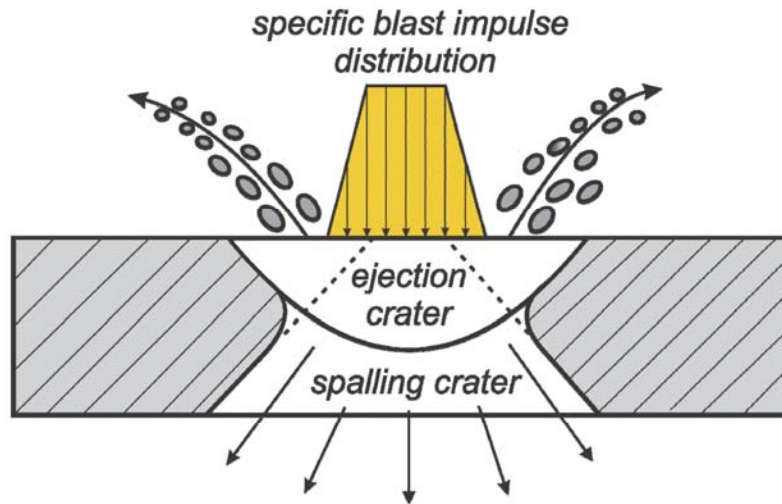

Figure 6. Mechanism of concrete breaching with contact charge

Table 4. Values of specific charge weight,  $K$

Material	$K$ (kg/m <sup>3</sup> )
Masonry	1.2 – 2.0
Plane concrete	2.5 – 3.0
Reinforced concrete (without cutting reinforcement)	8.4
Reinforced concrete (with partial cutting of reinforcement)	33.6

Case	Upper face	Lower face	Cross section	Failure mode
1				Crater Spall
2				Breach

Figure 7. Failure modes of concrete panels (reproduced with permission from (6))

EXPERIMENTAL STUDY OF LIGHTWEIGHT PROJECTILES PENETRATION IN CONCRETE WITH WASTE STEEL SHAVINGS AND RICE HUSK ASH

Indian Journal of Fundamental and Applied Life Sciences ISSN: 2231- 6345 (Online)

An Open Access, Online International Journal Available at [www.cibtech.org/sp.ed/jls/2014/03/jls.htm](http://www.cibtech.org/sp.ed/jls/2014/03/jls.htm) 2015

Vol. 5(S3), pp. 2695-2705/Barijani andEmamzadeh

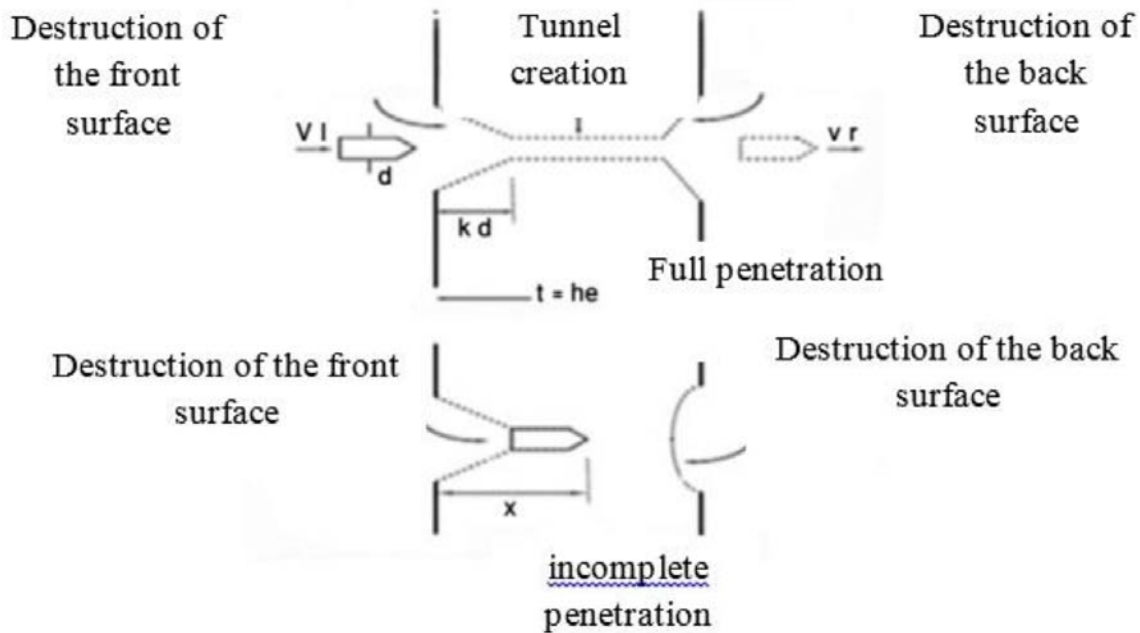

Figure 1: Full and Incomplete Penetration of the Projectile into the Concrete [6];  $kd$ = the Depth of Penetration into the Front Surface,  $d$  = the Diameter of the Projectile,  $he$ = the Thickness of the Specimen and Penetration Depth in the Case of Full Penetration,  $Vl$  = the Inlet Velocity of the Projectile,  $Vr$  = the Exit Velocity of the Projectile

Prediction of Hard Projectile Penetration on Concrete Targets

The 2016 World Congress on The 2016 Structures Congress (Structures16) Jeju Island, Korea, August 28- September 1, 2016

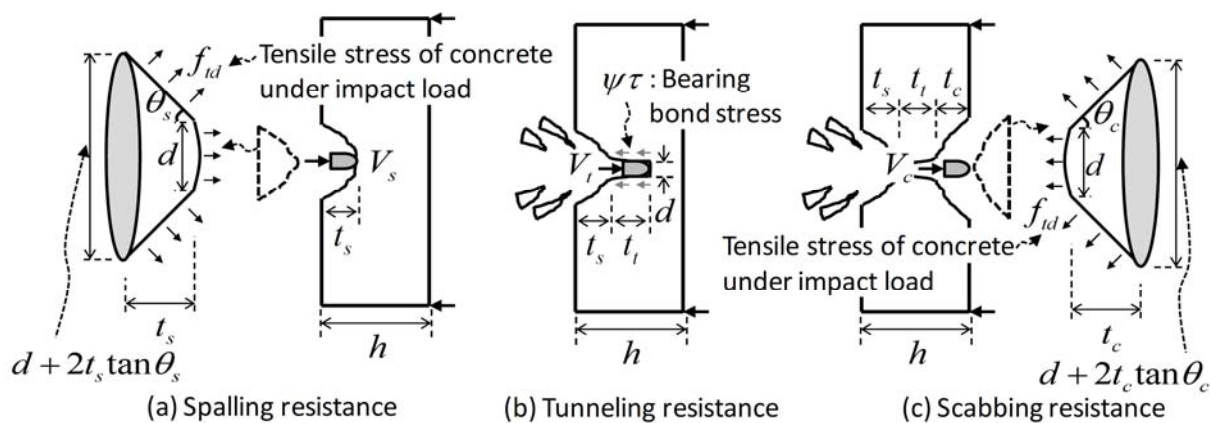

Fig. 2 Failure Mode of Concrete Targets

Study on the Analytical Behaviour of Concrete Structure Against Local Impact of Hard Missile

International Journal of Sustainable Construction Engineering & Technology Vol 1, No 2, December 2010

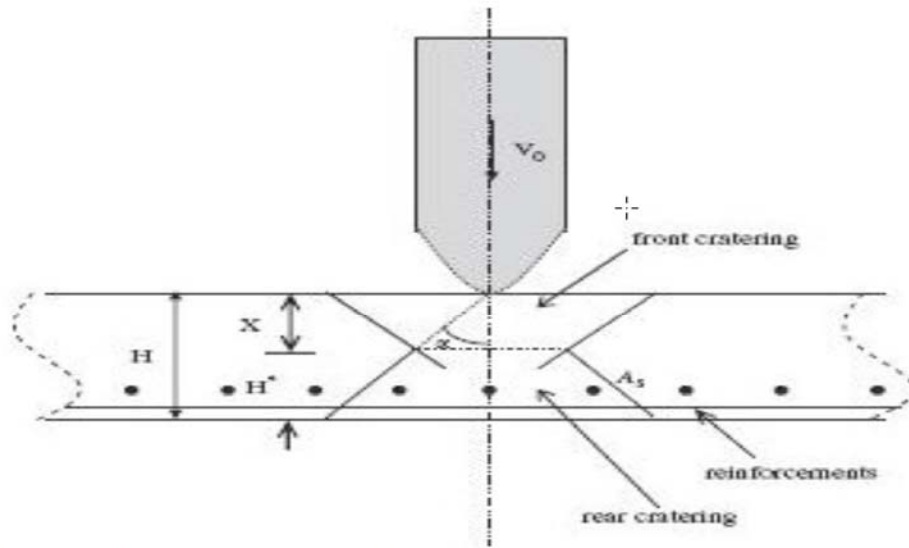

Fig. 8: Explains the Normal perforation of thin reinforced concrete targets (no tunneling process).

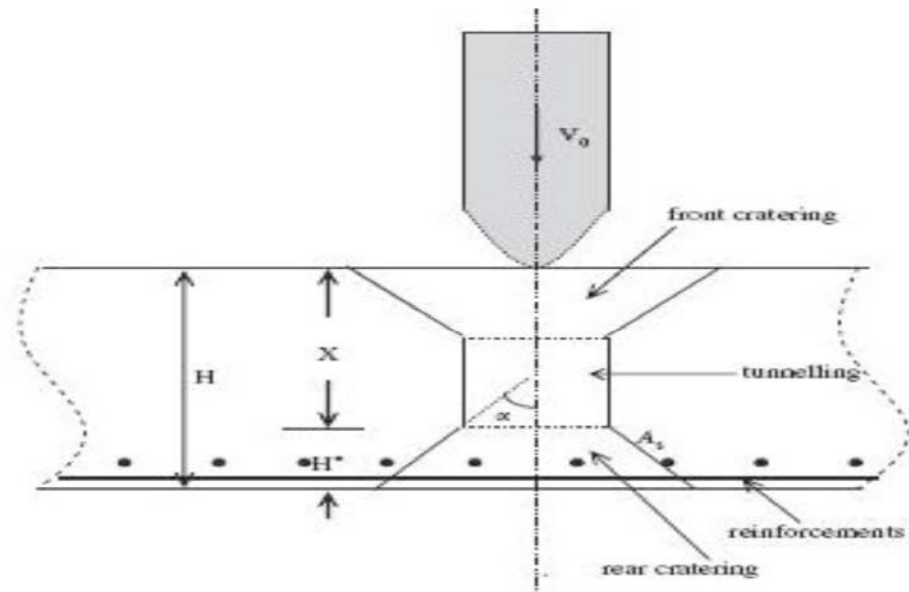
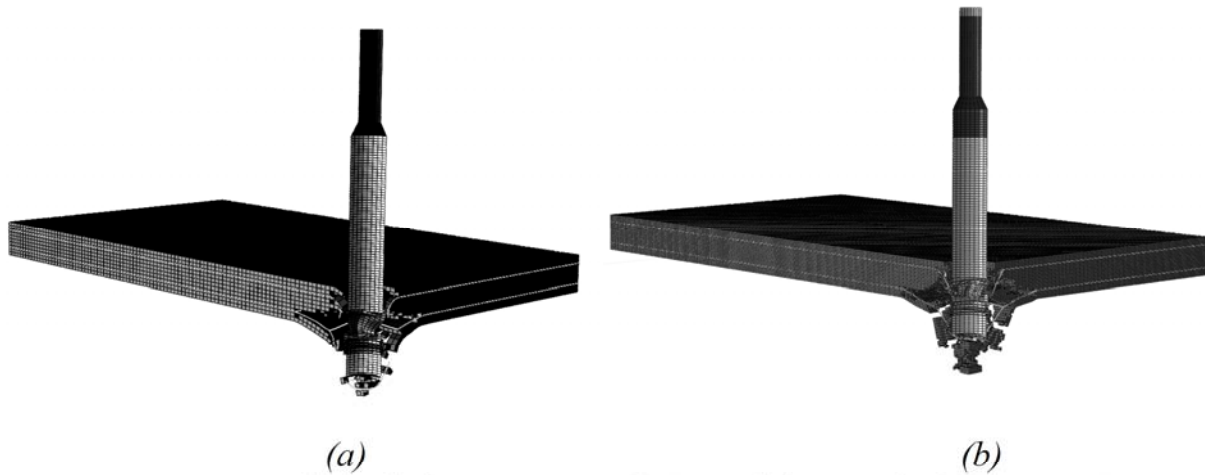
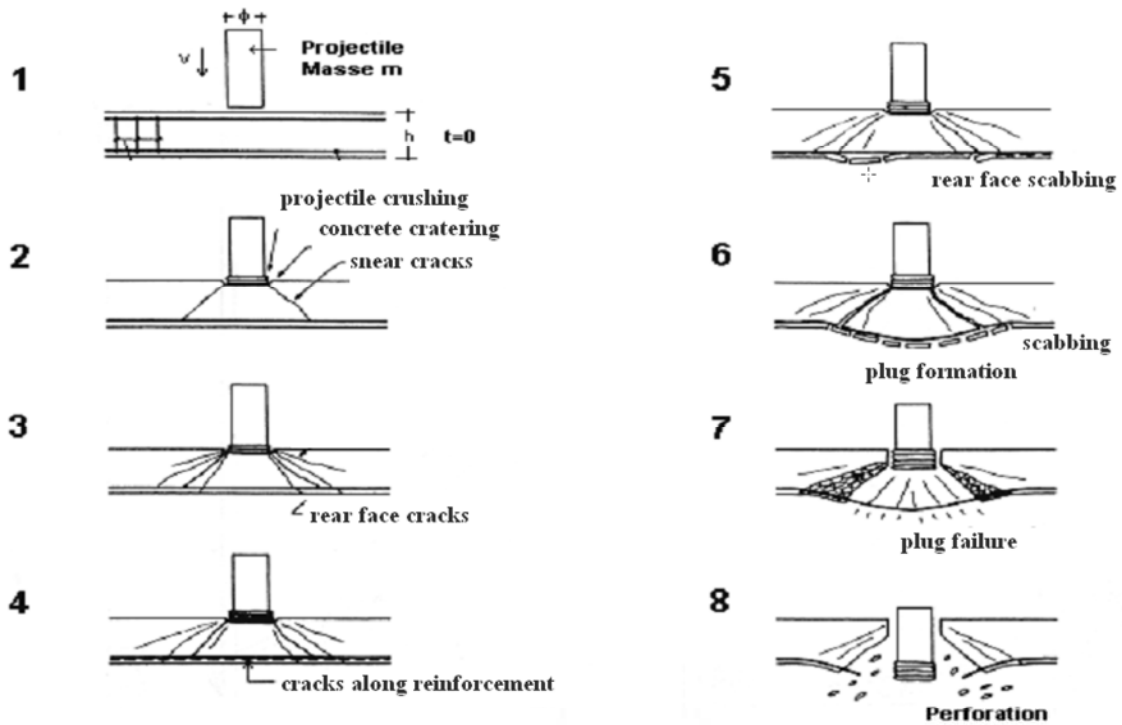

Fig. 9: Explains the Normal perforation of thick reinforced concrete targets.

Soft projectile impacts analysis on thin reinforced concrete slabs: Tests, modelling and simulations  
Revue. Volume X - n° x/annee, pages 1 a X



**Figure 20.** Numerical result for coarse mesh (a) and fine mesh (b) at 5 ms (test n°1,  $V_0 = 107.5$  m/s)



**Figure 1.** Successive steps of the process of soft impact on reinforced concrete slab (Jonas W. et al., 1982)



EMPIRICAL MODELS FOR PREDICTING PROTECTIVE PROPERTIES OF CONCRETE SHIELDS  
AGAINST HIGH-SPEED IMPACT

JOURNAL OF MECHANICS OF MATERIALS AND STRUCTURES  
Vol. 8, No. 2-4, 2013

202

GABI BEN-DOR, ANATOLY DUBINSKY AND TOV ELPERIN

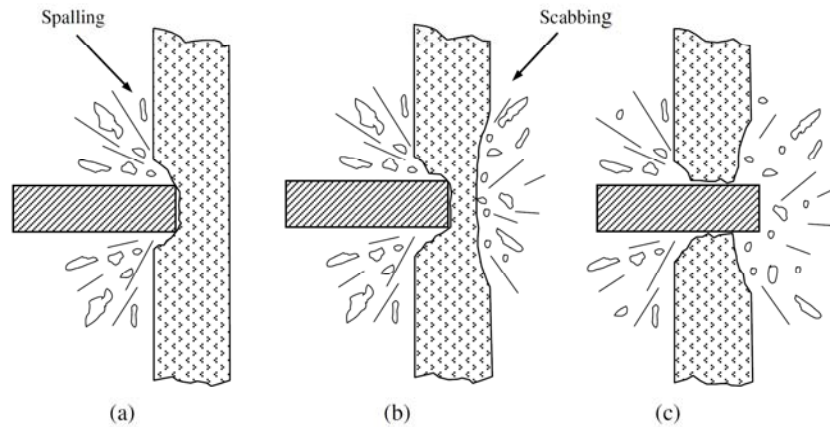

**Figure 1.** Local response of a shield: (a) penetration and spalling, (b) scabbing, and (c) perforation.

Meshfree modeling of concrete slab perforation using a reproducing kernel particle impact and penetration formulation

International Journal of Impact Engineering

<http://dx.doi.org/10.1016/j.ijimpeng.2015.07.009>

0734-743X/Published by Elsevier Ltd.

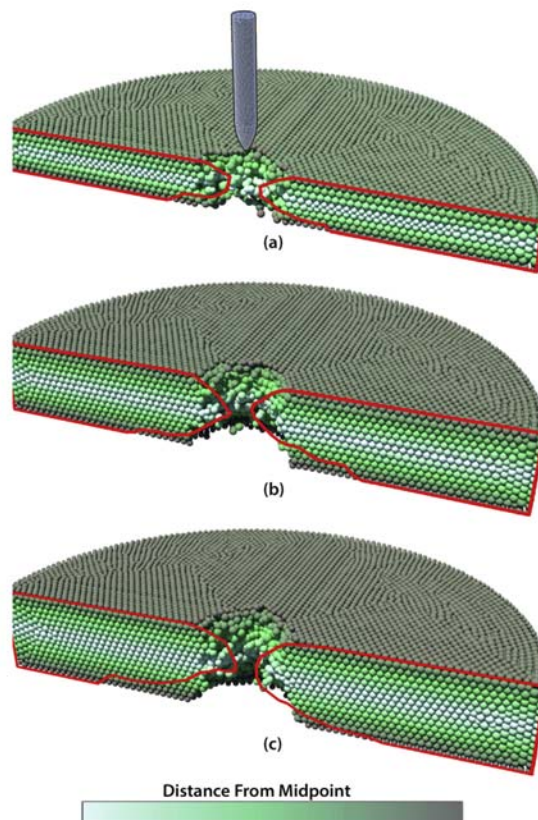

**Fig. 18.** Comparison of experimental and low resolution simulated impact and exit crater profiles for thicknesses of a) 127 mm, b) 216 mm, and c) 254 mm.

**Impact Speeds of Chlorine Cylinders Dropped from Different Heights**

Velocity at Impact (m/s)	Drop Altitude (m)	Drop Time (Seconds)
30	46	3
50	128	3
70	250	7
90	413	9
100	510	10

